

CNM non-marking vertical plate lifting clamps



The CNM clamp is equipped with 2 clamping jaws that are provided with special synthetic plastic. After hoisting, the clamp leaves no damage. The clamp is locked in the closed and open position.

Properties

- Equipped with synthetic plastic jaws.

Application

- For hoisting and transporting of, stainless steel, aluminum, wood and natural stone where the work-piece can not be damaged.

Norm:

- EN12100-1/2, EN13155, AS4991, ASME-B30,20

Safe workload when used under different angles

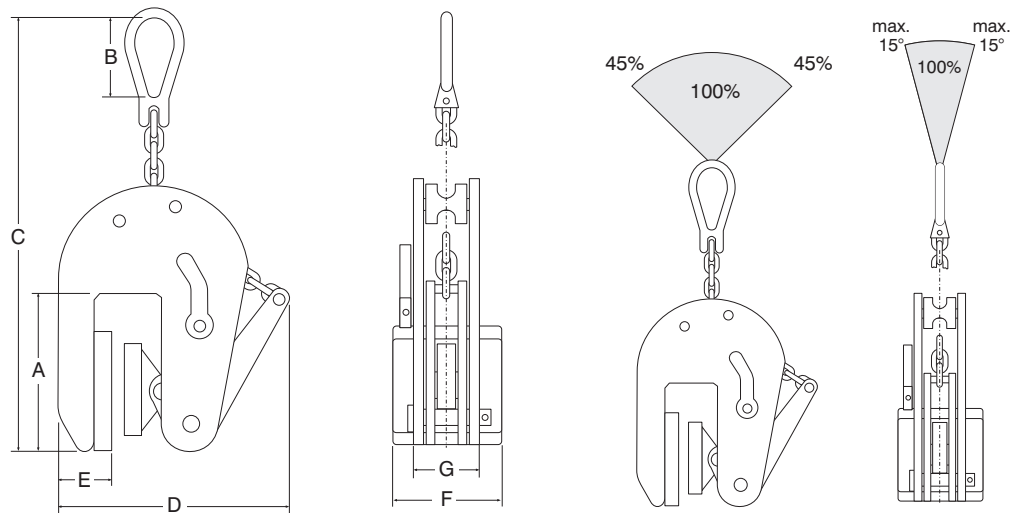

Type	WLL (kg)	Jaw opening (mm)	A (mm)	B (mm)	C (mm)	D (mm)	E (mm)	F (mm)	G (mm)	Weight (kg)	ProductId
CNM-0.5	500	1-20	102	65	462	224	48	80	48	6.0	3315001
CNM-0.5G	500	17-37	102	65	462	241	48	80	48	6.0	3315003
CNM-1.0	1000	1-30	105	80	470	282	46	80	54	6.5	3315000
CNM-1.5	1500	1-40	105	80	470	282	46	80	54	6.5	3315002
CNM-2.0	2000	1-50	124	100	704	408	63	80	65	15.0	3315004
CNM-3.0	3000	1-60	124	100	704	408	63	80	65	15.5	3315005